

Peer to Peer

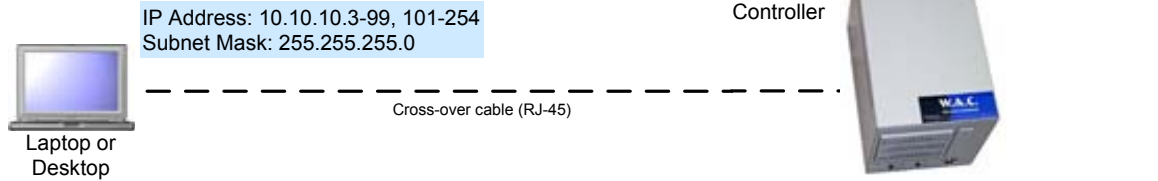

Peer to Peer with Hub

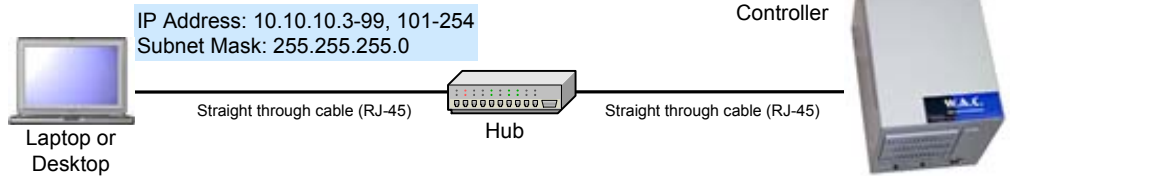

Network Configuration

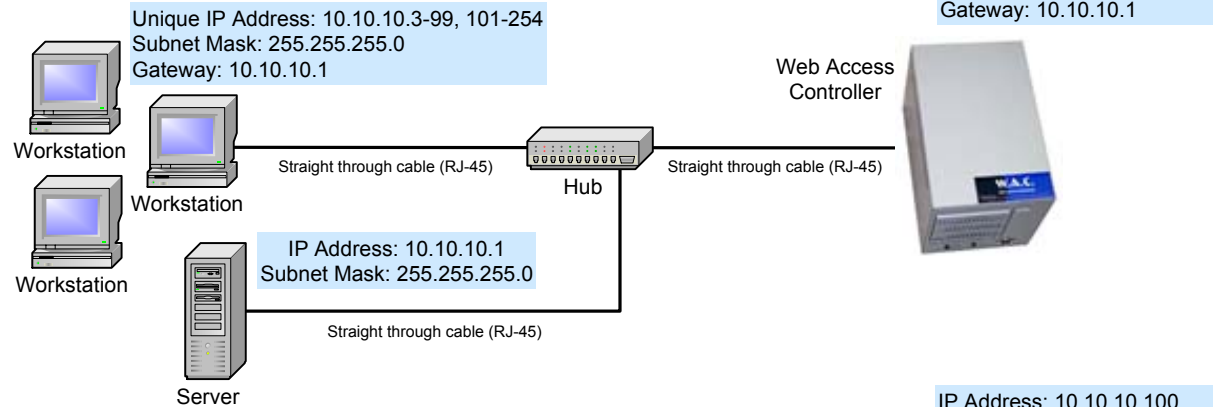

Modem Connection

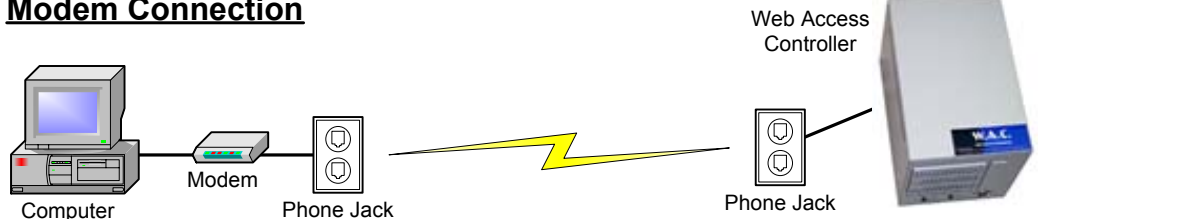

Setting up Windows IP Address/Subnet Mask

Windows 95/98/ME:

- 1) Click START..Settings..Control Panel.
- 2) Find and double-click the Network Icon.
- 3) Find the entry for TCP/IP associated with your network card, select it, and click the *Properties* button.
- 4) On the IP Address page, set the IP address to an available address from your IP block or private network.
- 5) Make sure the gateway and DNS configuration are set correctly; otherwise delete all gateway/DNS addresses.
- 6) Click on OK to close the TCP/IP Panel.
- 7) Click on OK again to close the Network Control Panel.
- 8) You may need to restart for the settings to take effect.

Windows NT:

- 1) Click START..Settings..Control Panel.
- 2) Find and double-click the Network Icon.
- 3) You should see the Identification page of the Network Control Panel.
- 4) Under Network Protocols, select TCP/IP Protocol and click on the *Properties* button.
- 5) In the Specify an IP Address panel, replace the IP Address/Subnet Mask with an available address from your IP block or private subnet.
- 6) Make sure the gateway and DNS configuration are set correctly; otherwise delete all gateway/DNS addresses.
- 7) Click on OK to get out of the TCP/IP Properties dialog.
- 8) You may need to restart your computer for your settings to take effect.

Windows 2000:

- 1) Click START..Settings..Network and Dial-up Connections.
- 2) Locate and double-click on your LAN connection.
- 3) You should see the Status dialog for this connection.
- 4) Under the list of components, select Internet Protocol (TCP/IP) and click on the *Properties* button.
- 5) For the IP address, enter an available address/Subnet Mask from your IP block or private network.
- 6) Make sure the gateway and DNS configuration are set correctly; otherwise delete all gateway/DNS addresses.
- 7) Click on OK to get out of the Internet Protocol(TCP/IP) properties dialog.

Windows XP:

- 1) Select Control Panel from the START menu.
- 2) Select Network and Internet Connections and then Network Connections.
- 3) Double-click the Local Area Connection icon under LAN or High-Speed Connection.
- 4) Click the Properties button in the Local Area Connection Status window.
- 5) Click Internet Protocol(TCP/IP) and then click the Properties button.
- 6) On the General tab, enter an available address/Subnet Mask from your IP block or private network.
- 7) Make sure the gateway and DNS configuration are set correctly; otherwise delete all gateway/DNS addresses.
- 8) Click OK, OK, and then Close to exit the Networking screens.



Chemtrac Systems, Inc.
6991 Peachtree Industrial Blvd. - Bldg. 600
Norcross, GA 30092
Phone: (770) 449-6233 (800) 442-8722 Fax: (770) 447-0889
chemtrac@chemtrac.com